	<h1>Sauer-Information</h1>	Mitteilung-Nummer: 0060/5N
	Inhalt: exhaust system overview 3-cylinder S950R C/E (63 kW / 86 HP)	Datum: 09.09.2009

Basic versions:

Version 1a (straight version):

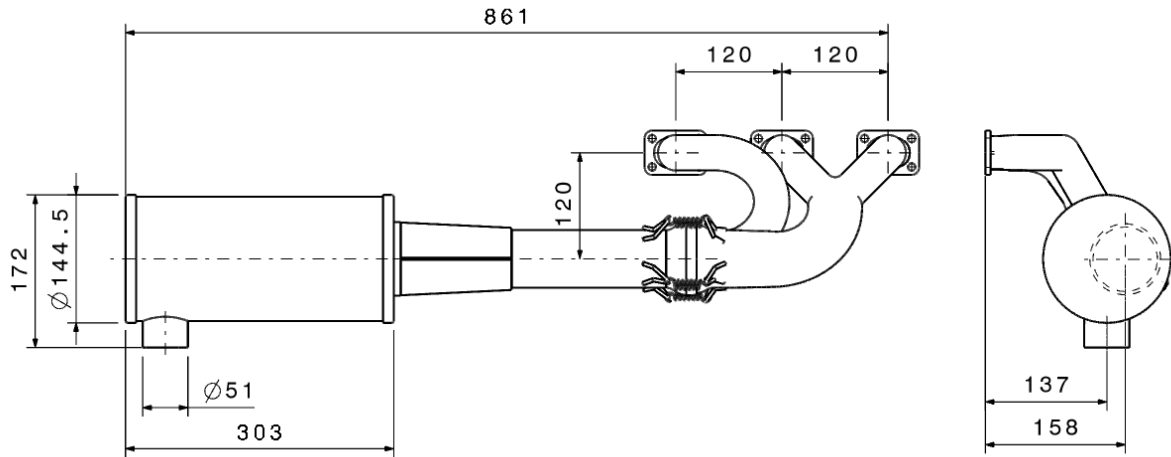

Version 1b (straight version):

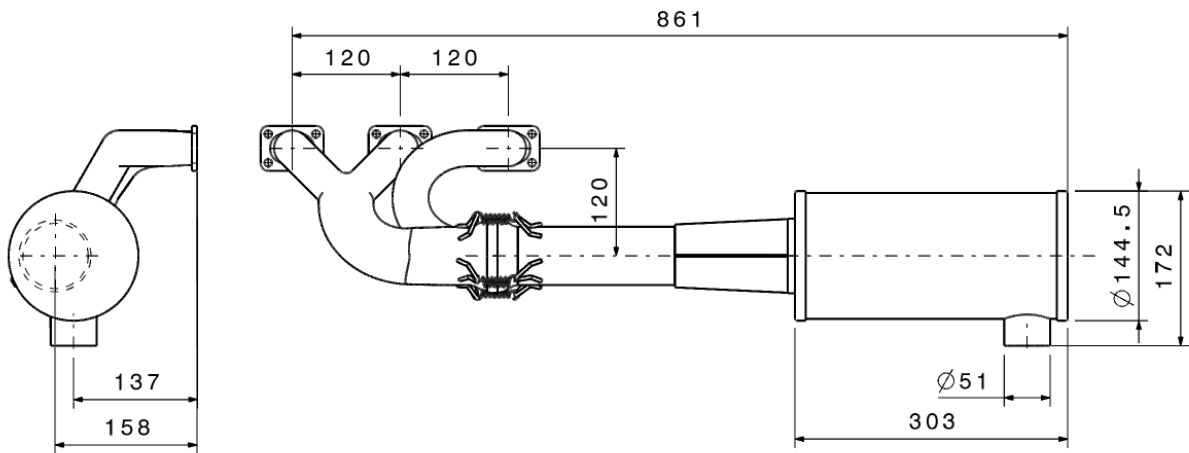

Note: The difference between version 1a and 1b are the outlet manifolds 378 A2U and 378 C2U being positioned in opposite.

Version 2a (90°-version):

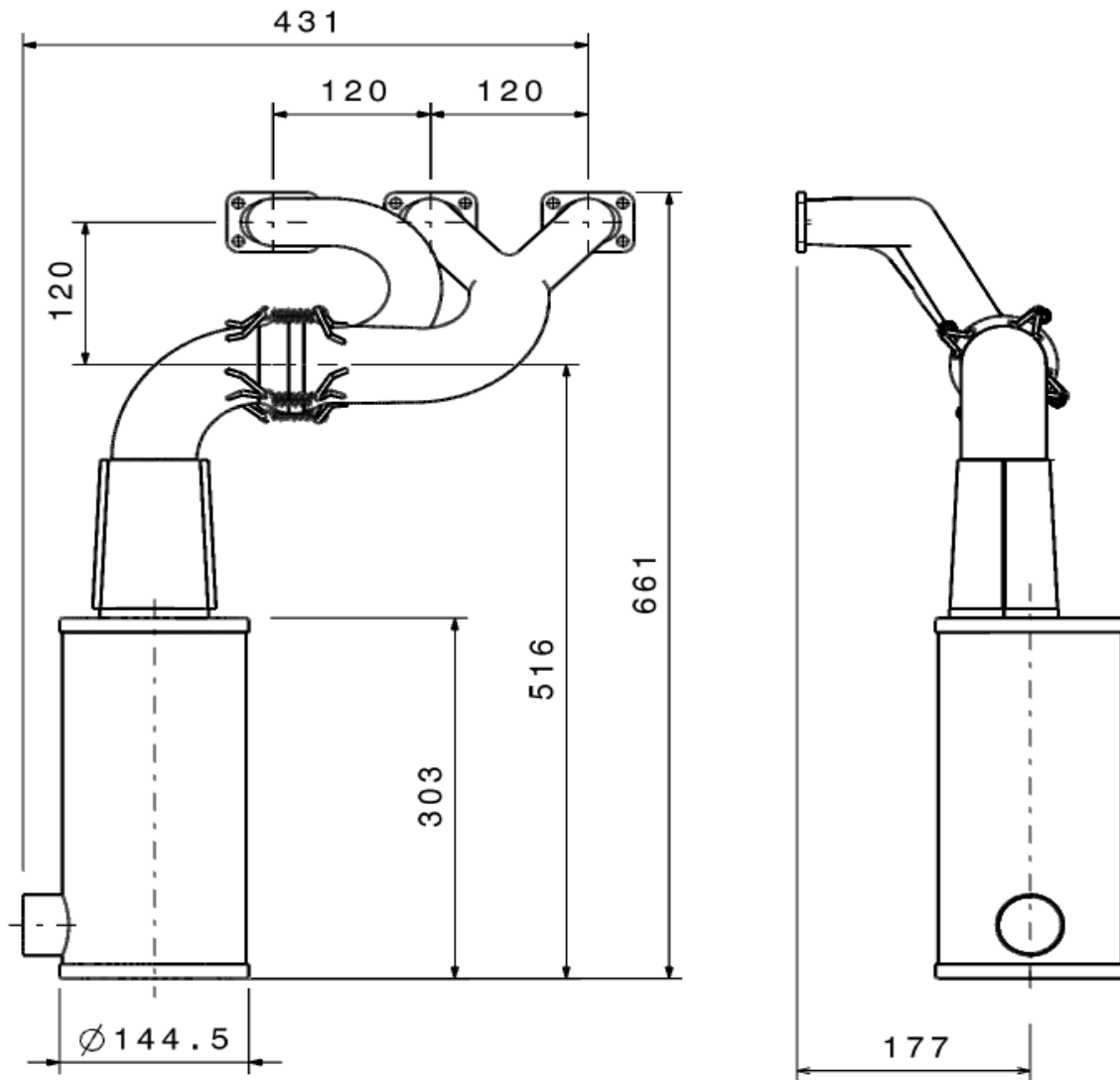

Version 2b (90° - version):

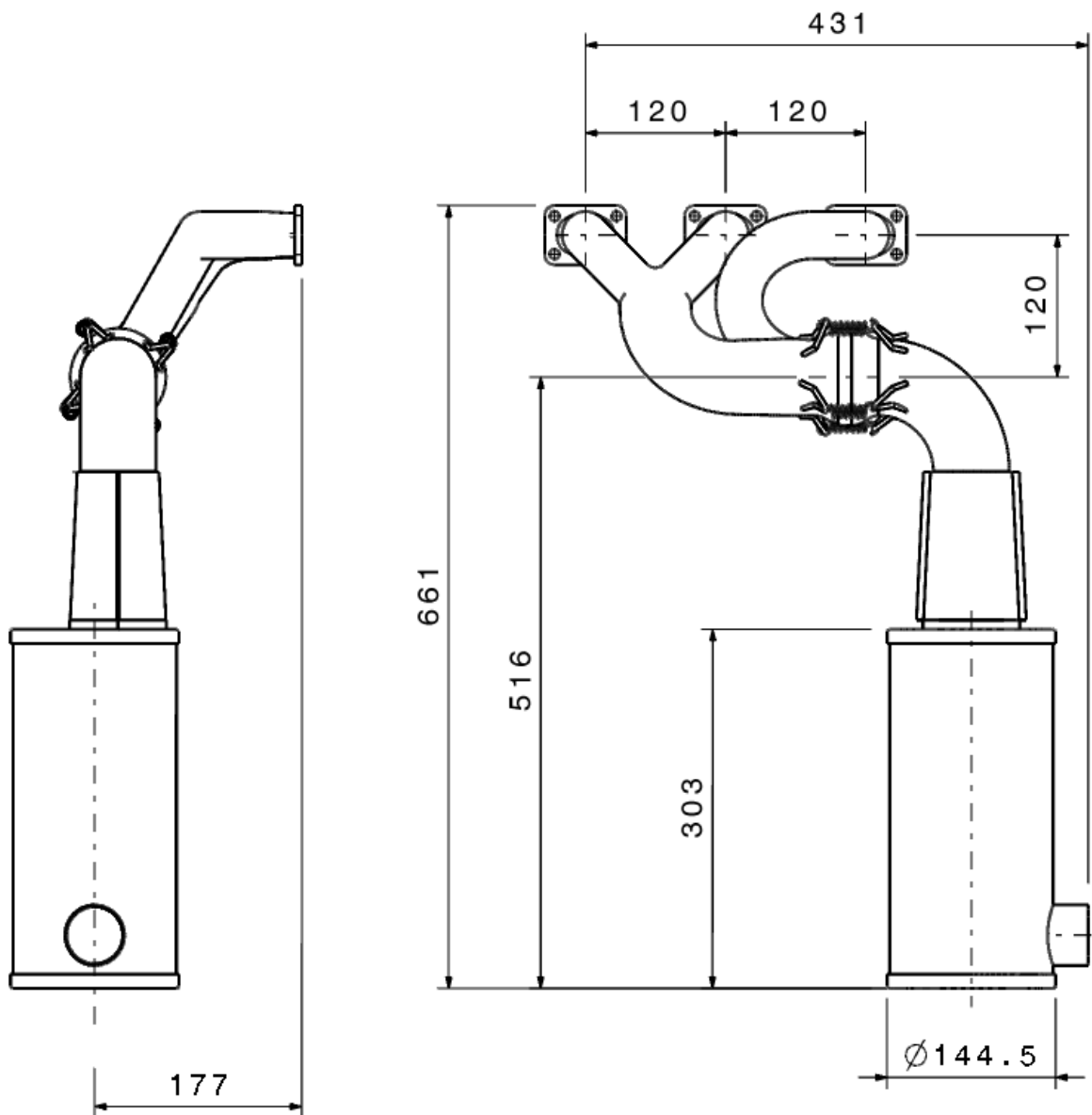

378S4U muffler, complete with fixing eye for rear muffler

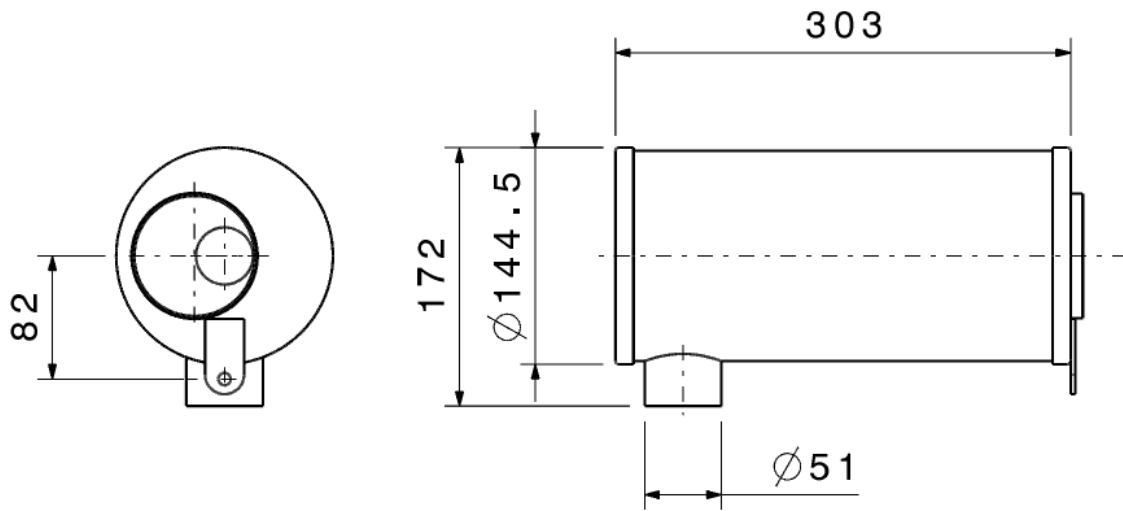

Version 3 (180°-version) complete with bracket, for direct mounting at the engine

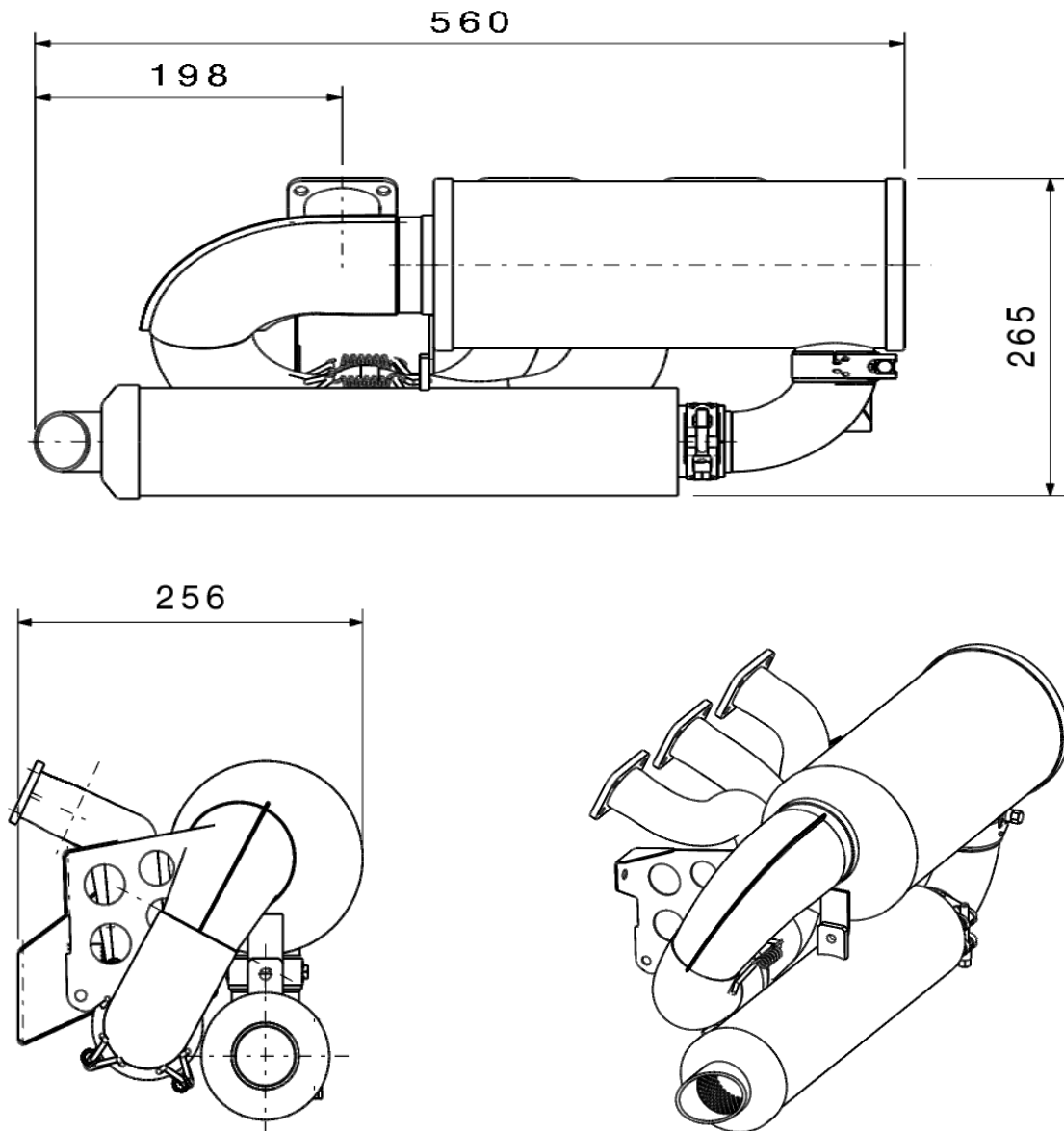

378A23U inlet pipe, complete

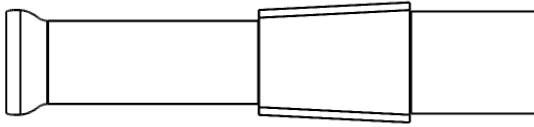

378A25U 90° - bow

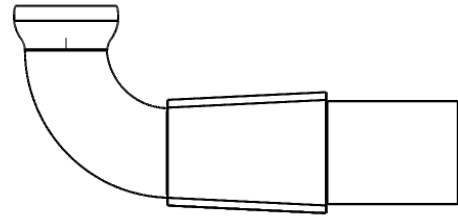

378A22U 180° - bow

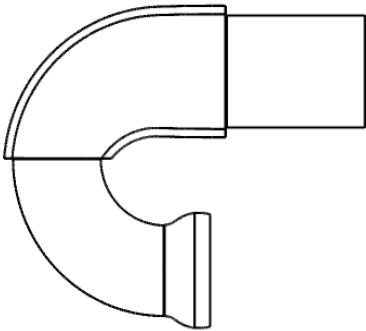

378S8U 90° - bow for rear muffler

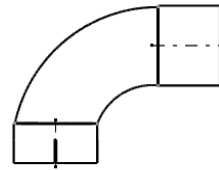

F308A4 eye



054.1 spring



063.35/1 clamp

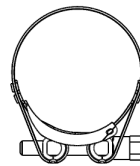

063.35/2 clamp



018.10/30 rear muffler





exhaust system basic versions in correspondence to engine model:

S950R (63kW (86HP)-Version):

	Var. 1a	1x	378A2U	outlet manifold (left)	
		1x	378A23U	inlet pipe (straight)	l = 0 mm
		1x	378S4U	muffler, complete	
or	Var. 1b	1x	378C2U	outlet manifold (right)	
		1x	378A23U	inlet pipe (straight)	l = 0 mm
		1x	378S4U	muffler, complete	
or	Var. 2a	1x	378A2U	outlet manifold (left)	
		1x	378A25U	bow (90°)	l = 0 mm
		1x	378S4U	muffler, complete	
or	Var. 2b	1x	378C2U	outlet manifold (right)	
		1x	378A25U	bow (90°)	l = 0 mm
		1x	378S4U	muffler, complete	
or	Var. 3	1x	378A2U	outlet manifold (left)	
			378A30U	exhaust system 180° with bracket, ready-to-install directly at the engine.	
				Contains bow (180°), muffler, rear muffler, mounting material.	
				End outlet in output direction	

Please note that the claimed performance of the engine can't be guaranteed if an exhaust system is used which is differing to one of the 2 basic versions (see page 1). Resulting from any modifications or changes of the exhaust system the engine might be damaged and in this case we are not obliged for any warranty or guarantee.

The at the engine S950R (63 kW / 84 HP) noted length l = 0 mm means, that the cone pipe 378A23U, 378A25U or 378A22U is introduced completely into the muffler (378S4U). The lengths differing from 0 refer to the spaces stated as „l“ in the sketches.